

K-8 Karakorum Jet Trainer

64mm EDF RC JET

SPECIFICATIONS

Wingspan: 930mm
Length: 1026mm (without pitot tube)
Dry weight: 530g
Flying weight: 1150g (Full loading)
Wing loading: 72.6g/dm ²

ELECTRONIC

Power System: 6S/4S 64mm EDF x 1
ESC: 40A ESC x 1
Servos: 9g servos x 8
Battery: 6S/4S Lipo
Radio: 6 Channel TX and RX

RECOMMENDED BATTERY

4S Version: 2200-2600mAh 4S Lipo; 6S Version: 2200-4200mAh 6S Lipo.

KIT TYPE

KIT	KIT + Servos	PNP
Shock Absorber	KIT	KIT
Landing Gear	9g Servo x 8 (Installed)	9g Servo x 8 (Installed)
		40A ESC x 1 (Installed)
		4S: 2840-3200KV 64mm EDF (Installed)
		6S: 2840-2300KV 64mm EDF (Installed)

CONTENTS OF KIT

- | | | |
|----------------------------|--|--|
| 1. Fuselage*1 | 9. Landing Gear L*1 | 16. Front Wheel Pushrods*1 |
| 2. Left Wing*1 | 10. Landing Gear R*1 | 17. Screws for wings*4 (Silver) |
| 3. Right Wing*1 | 11. Drop Tank Pylon * 2
(Installed for Kit+S/PNP) | 18. Screws for Horizontal stabilizer*2 |
| 4. Horizontal Stabilizer*1 | 12. Aileron Pushrods*2 | 19. Screws for EDF*2 (Black) |
| 5. Drop Tank L*1 | 13. Flap Pushrods*2 | 20. Front Wheel Steering Arm*1 |
| 6. Drop Tank R*1 | 14. Elevator Pushrods*2 | 21. Pitot Tube*1 |
| 7. Wing Tube*1 | 15. Rudder Pushrods*2 | 22. Velcro*1 |
| 8. Front Wheel *1 | | |

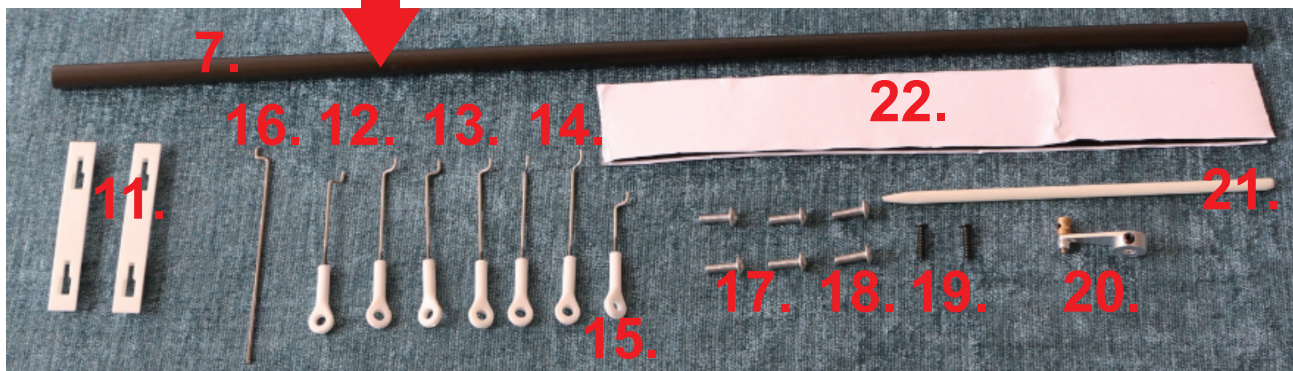

Model Assembly

Horizontal stabilizer Servo

1. Set 9g servo to neutral point and screw on Servo arm. Glue the servo into the slot on the Horizontal Stabilizer. Suggested cable length is 15cm.

NOTE: Require 1 normal and 1 reverse 9g Servo.

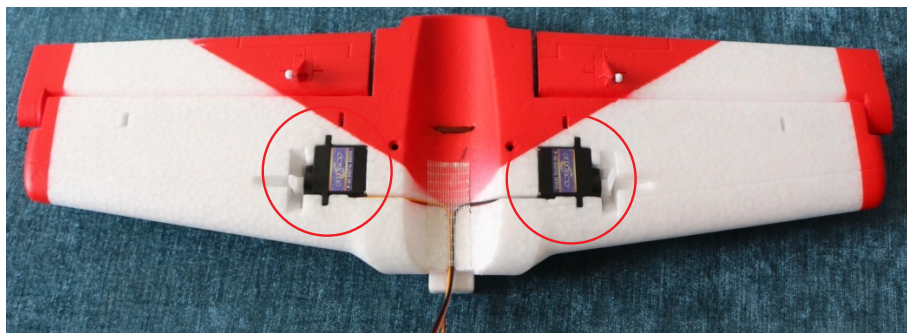

2. Adjust pushrods length then link the Servo arm and Control horn.

NOTE: We recommend using the 3rd hole on the servo arm

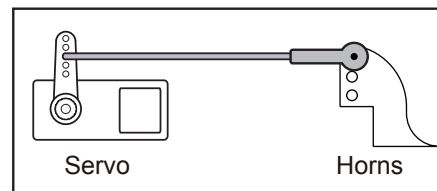

Flap and Aileron Servo

3. Set 9g servos to neutral position and screw on the Servo arms.

Glue servos into the slot, making sure the flap servo is in the correct starting point and correct flap movement direction.

Caution: We recommend using the 3rd hole on the Servo arm.

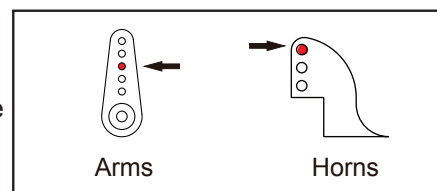

4. Align all cables along the cable slot. Glue Drop Tank pylon slot into the wing.

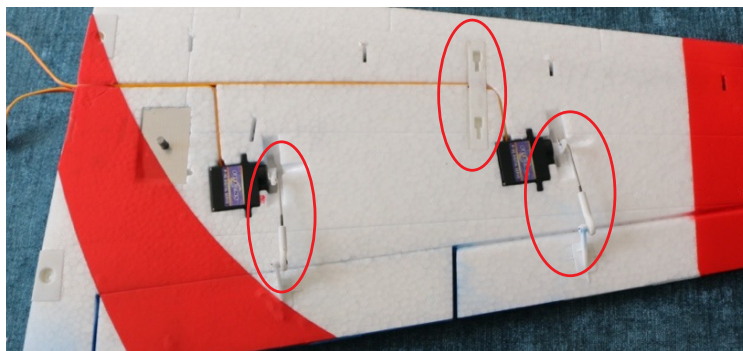

5. Same procedure with the other Wing.

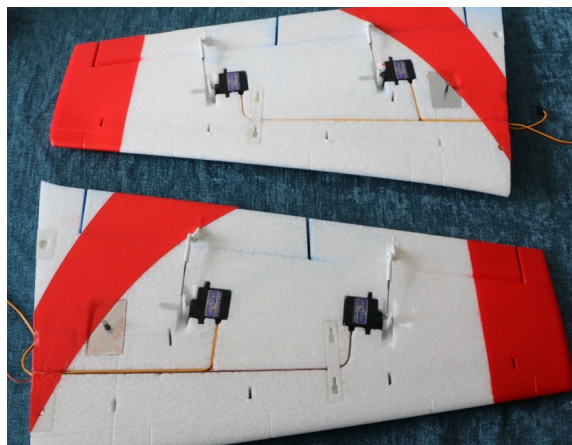

Rudder Servo

6. Set 9g servo to neutral position and screw on Servo arm. Glue the servo into the slot on the Rudder.
7. Adjust pushrods length then link the Servo arm and Control horn.

Caution: We recommend use the 2nd holes on Servo arm.

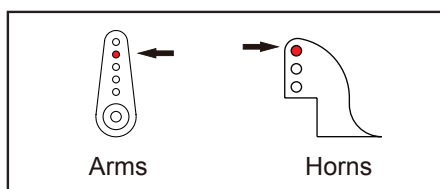

Horizontal Stabilizer

8. Connect two Servo leads from the Horizontal Stabilizer to the Y cable, Insert the cable into Fuselage.

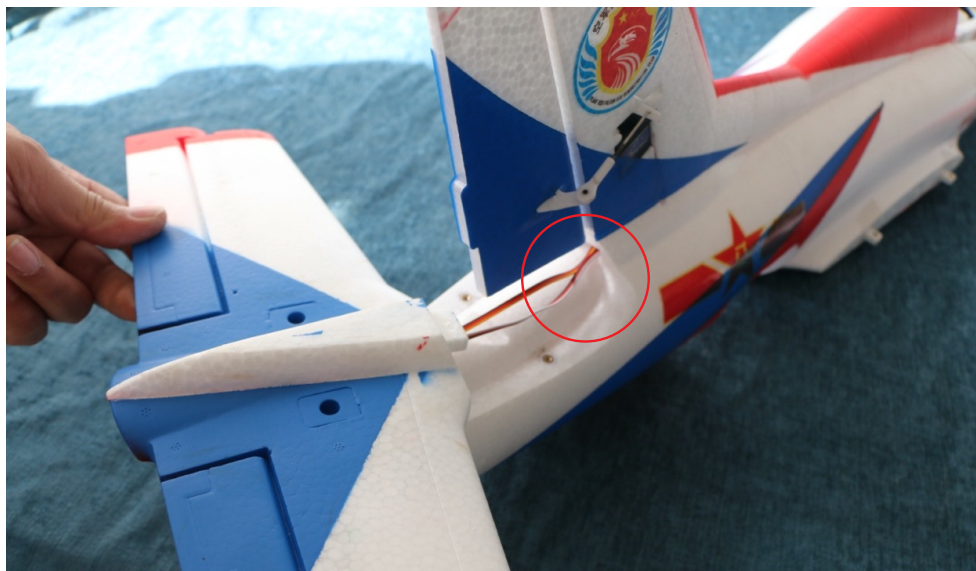

9. Install Horizontal Stabilizer onto fuselage.
Tighten the screws with 2.5mm hexagon key.



EDF & ESC

10. Install ESC into the ESC compartment and connect the 3 power leads to the EDF. Test the EDF to ensure the blades spin in the correct direction. If the blades are spinning in reverse swap any of the two motor leads.

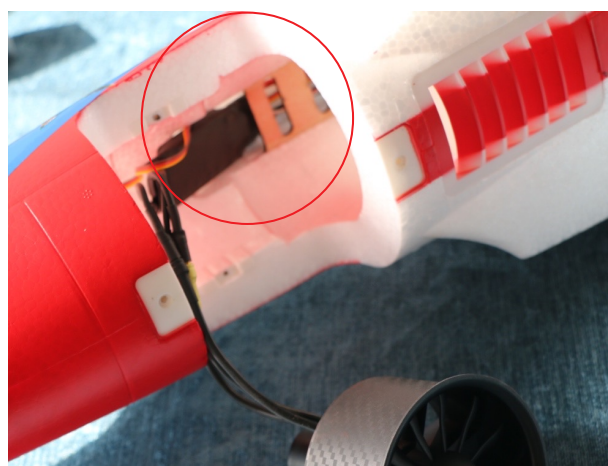

11. Install the EDF using the 2 x black screws.



12. Install the EDF cover and secure with the provided screws



Landing gear Installation

13. Install the main landing gears, ensuring that the springs are facing forward.

- For a scale look, Position the main landing gears with the wheels inboard.
- For a more stable taxiing, position the wheels outboard.

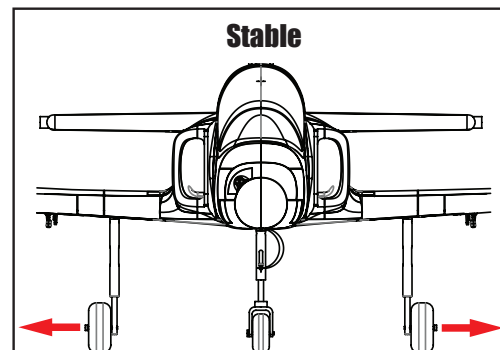
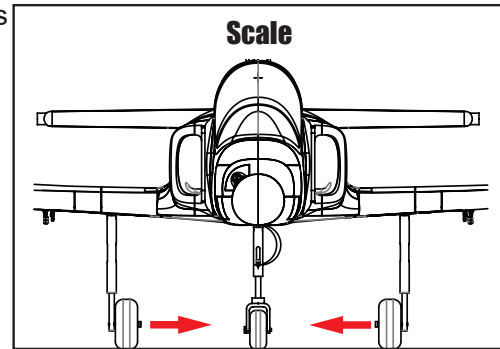

14. Install nose landing gear and tighten the screw.



15. Link Front Wheel Steering Arm and servo arm with push rod.

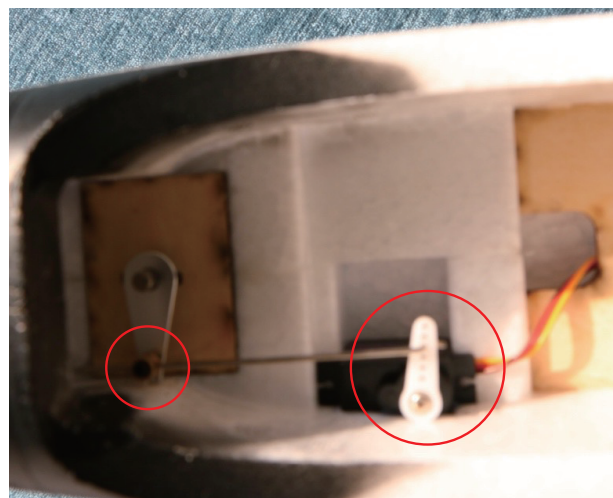

Main Wing installation

16. Insert the carbon spar into fuselage.
Following the labels in the servo leads, connect the Aileron and Flap servos.

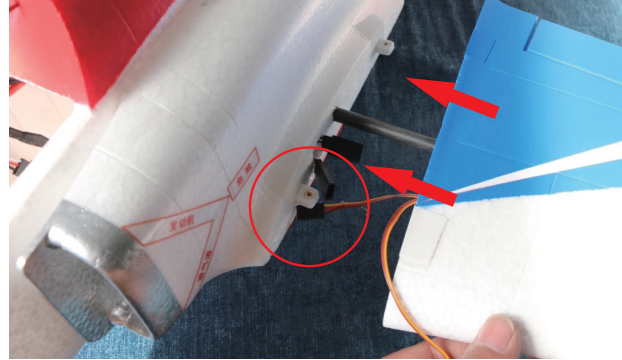

17. Install both wings and secure with screws.



Accessories

18. Slide both Drop Tanks into the wing Pylon



19. Install Pitot tube onto Nose cone.

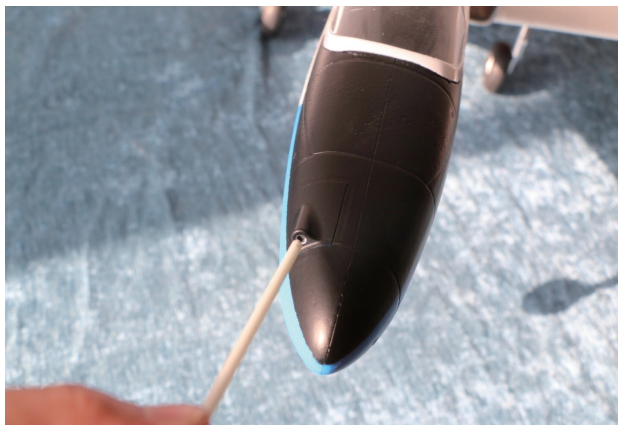

Flight Setup

Check the C.G.

The Center of Gravity (CG) location is 63mm from the leading edge of the main wing (as shown) with the battery pack installed.

The center of gravity can be adjusted by moving the battery forward or aft.

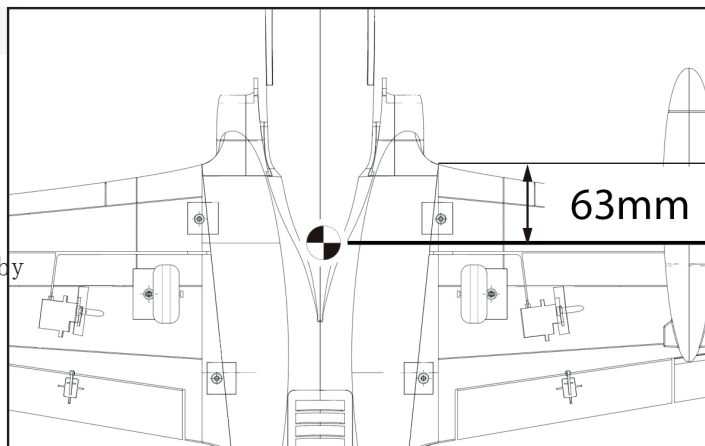

Model Setup

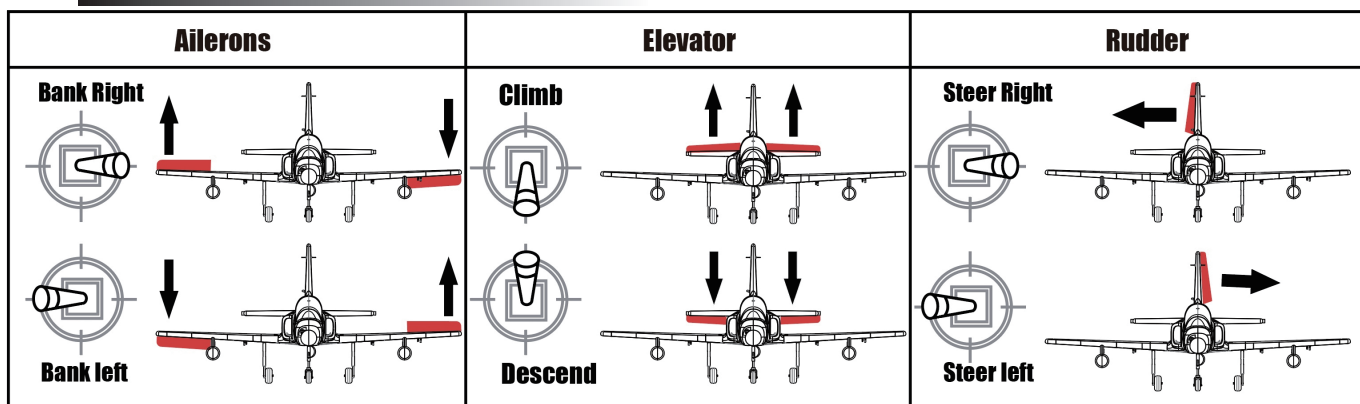

Model Setup

We recommend using dual rates for a better flying experience.

For takeoff and landings, using Low rates on the Elevator and ailerons provided for a smoother rotation on takeoff.

During ground taxiing the use of the recommended high rates provided better steering authority.

In flight we recommended the use of Low rates for scale flying and using the high rates for extreme maneuvers.

	High Rate	Low Rate
Elevator	80-90%	35-45%
Aileron	90-100%	45-55%
Rudder	80-90%	35-45%
Flap	75-85%	40-50%

CAUTION

The travel range of the Flaps servo is 90 degrees. Please limit the Flaps travel to 85 degrees to avoid damage to the aircraft and prevent binding of the servo.

Tips

- Move the battery forward or aft as necessary to achieve the recommended CG for your maiden flight. Readjust the position of the battery after your maiden to suit your flying style.
- During landing configuration, the use of full flaps will slow the plane down quickly. Please be aware your airspeed to avoid stalling.